

DOOR OPERATOR EQUIPMENT

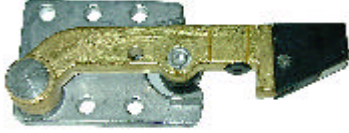

Stock	GAL#	Description
G001	INT-1-4RH	MO Keeper, R.H.
G002	INT-1-4LH	MO Keeper, L.H.



Stock	GAL #	Description
G003	INT-2-1	Dual Interlock Switch



Stock	GAL #	Description
G004	INT-2-23	MOCPS Keeper



Stock	GAL #	Description
G005	INT-1-15RH(MOKT)	Door Contact Kit, R.H.
G006	INT-1-15LH(MOKT)	Door Contact Kit, L.H.



Stock	GAL #	Description
G007	SW-G-1	Gate Switch

PICK UP ROLLER Assy.



Stock	GAL #	Description
G013	INT-1-9-1-RH	Horizontal Release, R.H.
G014	INT-1-9-1-LH	Horizontal Release, L.H.



Stock	GAL #	Description
G010	INT-1-1-RH	MO Interlock Switch, R.H.
G011	INT-1-1-LH	MO Interlock Switch, L.H.



Stock	GAL #	Description
G012	SWC-1-445	Gate Contact Kit

HATCH DOOR DRAWINGS

CENTER OPENING

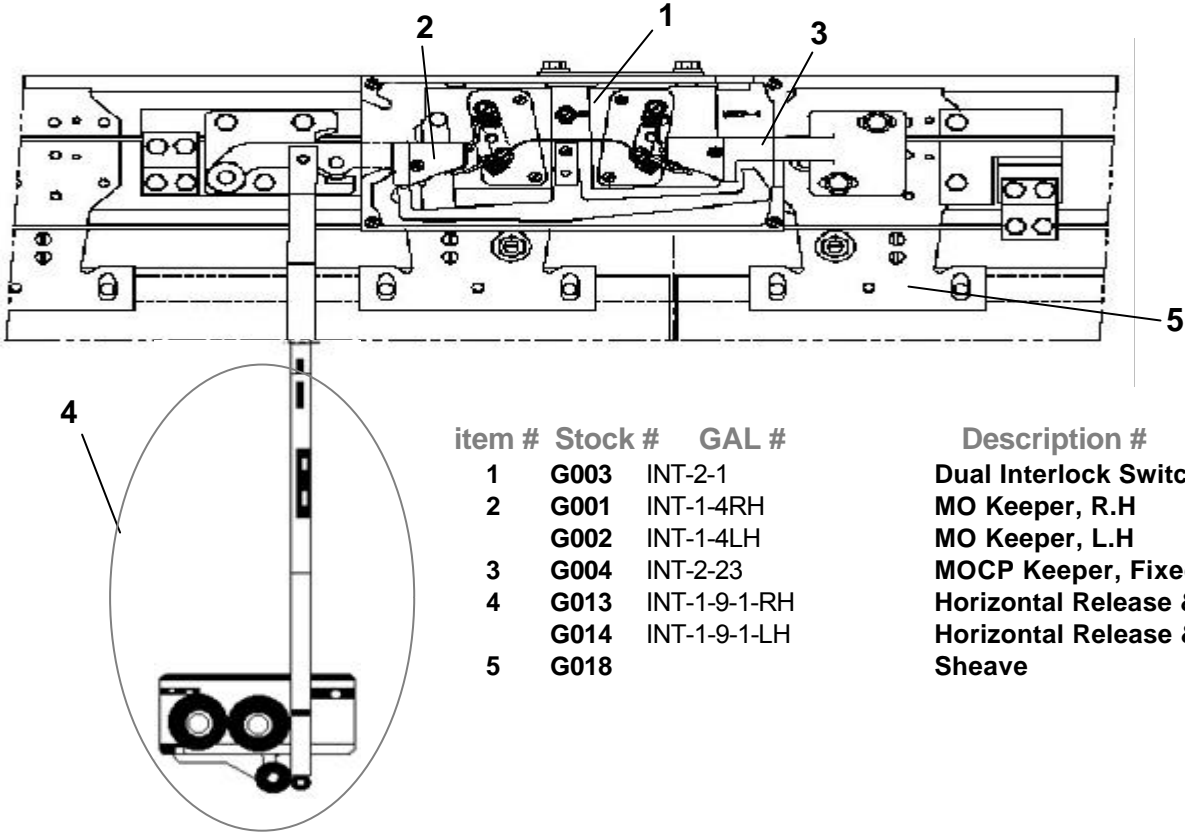

item #	Stock #	GAL #	Description #
1	G003	INT-2-1	Dual Interlock Switch
2	G001	INT-1-4RH	MO Keeper, R.H
	G002	INT-1-4LH	MO Keeper, L.H
3	G004	INT-2-23	MOCPS Keeper, Fixed
4	G013	INT-1-9-1-RH	Horizontal Release & links, R.H
	G014	INT-1-9-1-LH	Horizontal Release & links, L.H
5	G018		Sheave

SIDE OPENING

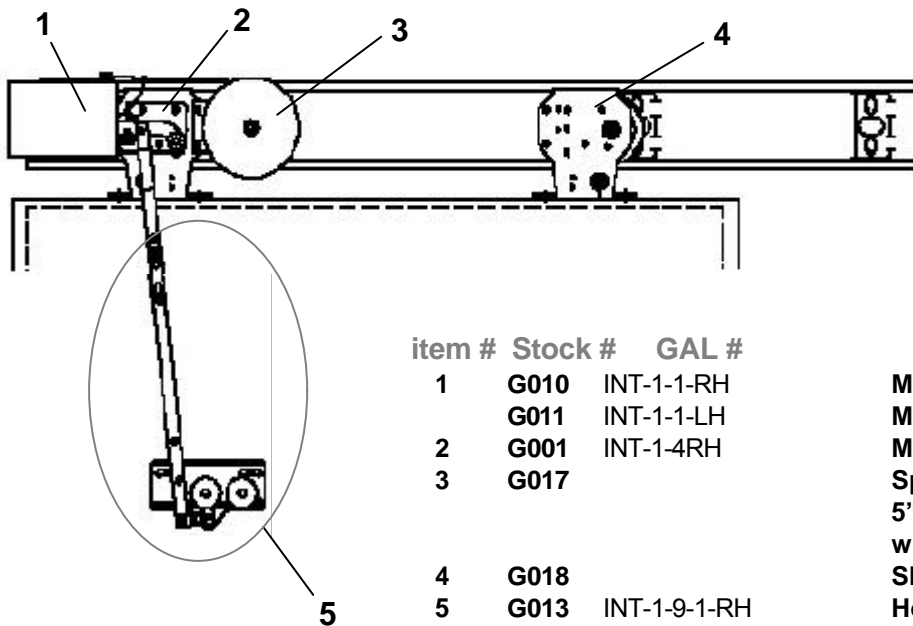

item #	Stock #	GAL #	Description #
1	G010	INT-1-1-RH	MO Interlock Switch, R.H.
	G011	INT-1-1-LH	MO Interlock Switch, L.H.
2	G001	INT-1-4RH	MO Keeper, R.H.
3	G017		Spirator, L.H
4	G018		5" dia, real type door closer with mounting bracket
5	G013	INT-1-9-1-RH	Horizontal Release & links, R.H
	G014	INT-1-9-1-LH	Horizontal Release & links, L.H