

MAIN SHAFT, DIA. 1.545"

INDUCTION MOTOR, 3 HP.

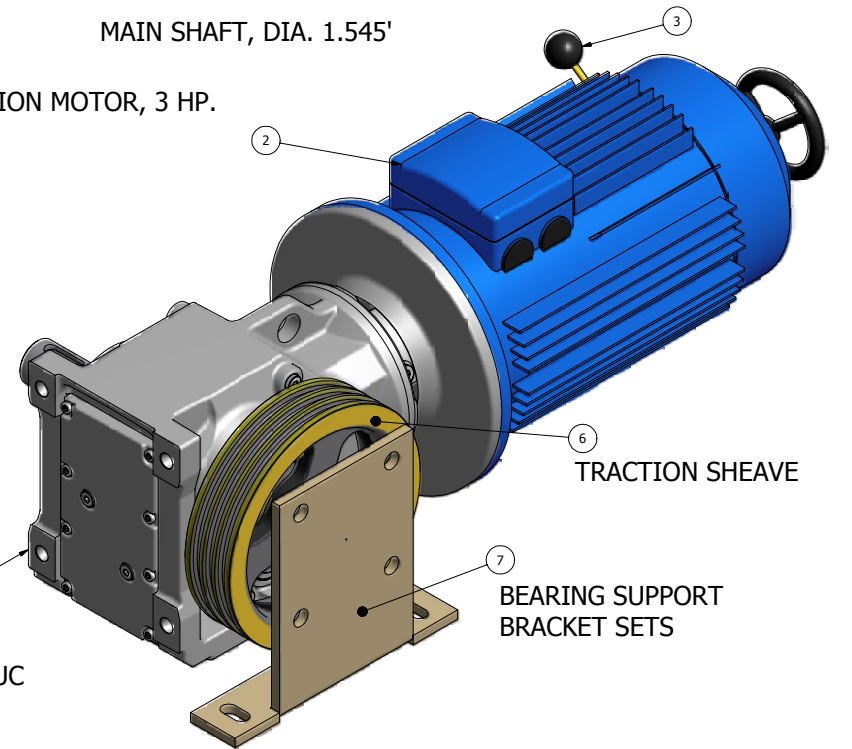
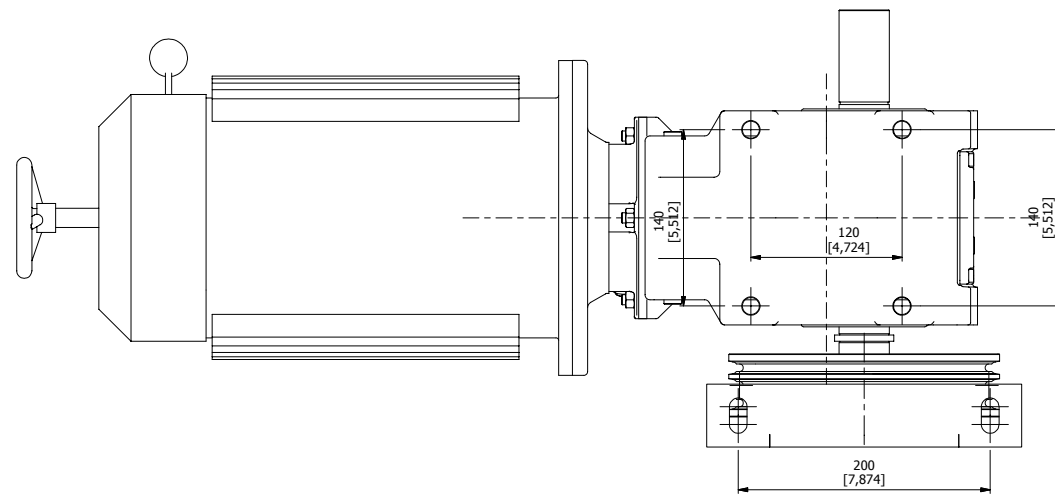

GEARBOX\_B-083\_UC

Parts LIST						
ITEM	QTY	PART NUMBER	품명	재질	규격및도면	비고
1	1	GEARBOX_B_083-UC	MOTORVARIO GEARBOX			
2	1	I-MOTOR	INDUCTION MOTOR, 2 HORSE POWER, 1.5KW			
3	1	BREAK DC100V	MOTOR BREAK, MANUAL HANDLE			
4	1	UCP BEARING	VERTICAL OR PILLOW BEARING AS OPTIONAL ITEMS			
5	1	SHAFT40	MAIN SHAFT, DIAMETER 1.545 INCH			
6	1	T-SHEAVE	TRACTION SHEAVE, RIM DIAMETER, 8.46 INCH			
7	1	S-BRACKET	BEARING SUPPORT BRACKETS			

UNIT	SCALE	PROJECTION	3rd ANGLE	DWG SIZE	WEIGHT	MATERIAL	Sheets
mm				A2	kg		2
DRAWING	DESIGN	CHECKED	APPROVED	TITLE			
Administrator				SHEAVE HOISTING MACHINE			
2017-01-11				2017-01-11			
				PROJECT		FILE NAME	
				SOUTHEAST ELEVATOR		SHAFT40.idw	
DWG' NO.				GEARBOX		DWG' DATE	
						2017-01-11	